

# Carat

The *Carat* is a high-strength underground tank available in 1000 gallon and 1700 gallon capacities. It is assembled from two half-sections joined at the middle with a reliable gasket and clamping system, a feature that makes it possible to stack many tanks on a single shipping pallet and then hand-carry the components to the excavation. A compartment on the top of the tank called a *dome* swivels in any direction and has sufficient space for an internal filter and controls. A telescopic riser with a sturdy lid slides into the dome and provides height adjustment so that the lid can be positioned flush with the ground surface.

Unlike most plastic cisterns, the *Carat* is designed to be fully emptied for long periods of dry weather. With an extension and a heavy-duty riser, it is strong enough to be buried 48" below grade. With a heavy-duty riser and a cast-iron lid it is strong enough for use under residential driveways and parking areas.

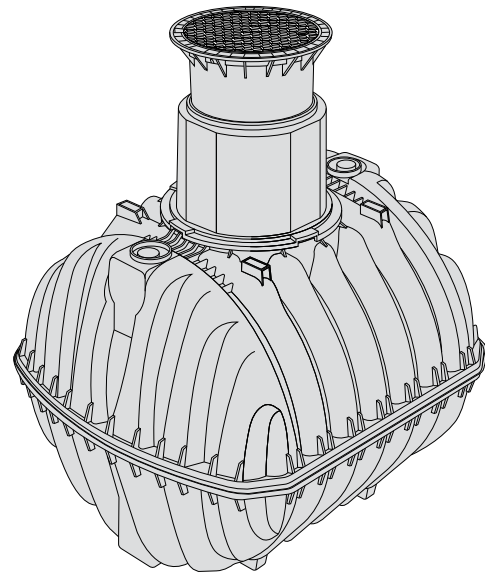

## DIMENSIONS WITH STANDARD RISER

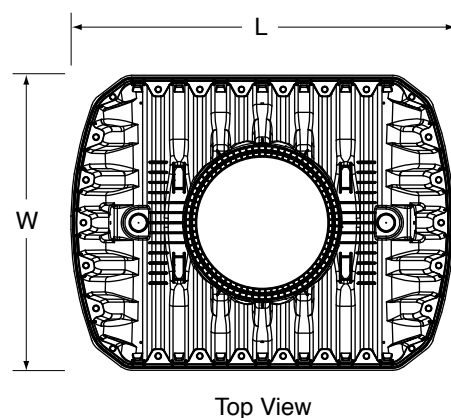
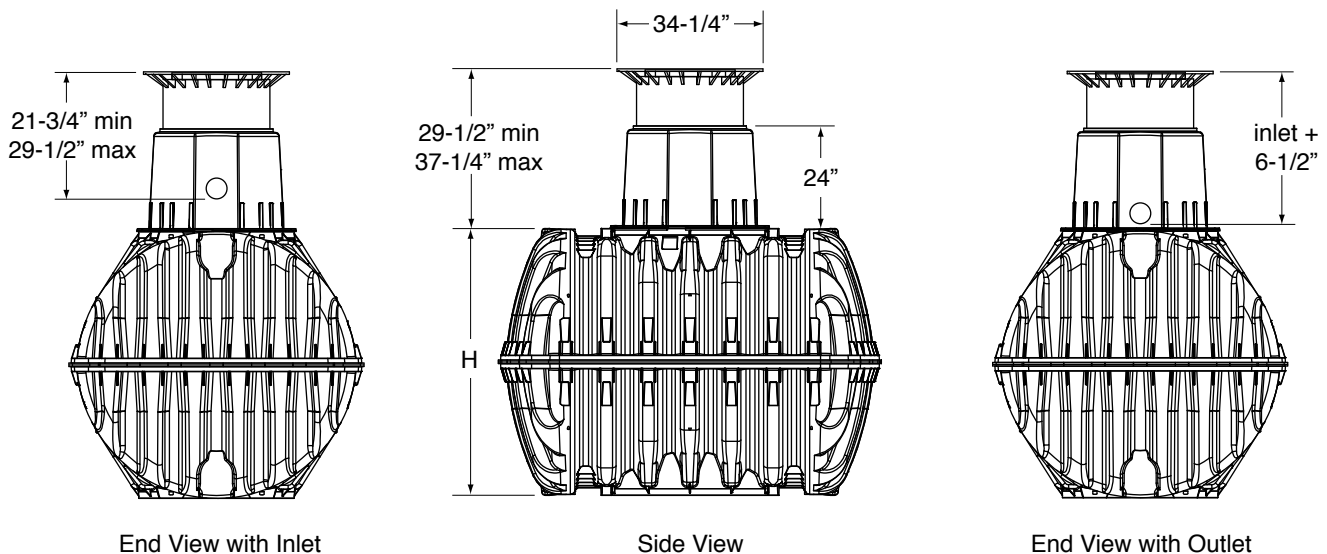

	1000 gal	1700 gal
<b>L</b>	89-3/4"	94"
<b>W</b>	69"	86-1/4"
<b>H</b>	62-1/2"	82-1/2"

- excavate at least 6" below tank bottom
- excavate at least 18" beyond all sides